

LAZAROPOLE- VILLAGE OF MIJACS

-ONE OF THE HIGHEST (1350M) & MOST BEAUTIFUL VILLAGES IN THE COUNTRY.
 -THE VILLAGE HAS COZY MOUNTAIN-CONTINENTAL CLIMATE.
 -LAZAROPOLE IS KNOWN FOR ITS LOCAL TRADITIONAL ARCHITECTURE

SITE ANALYSIS :

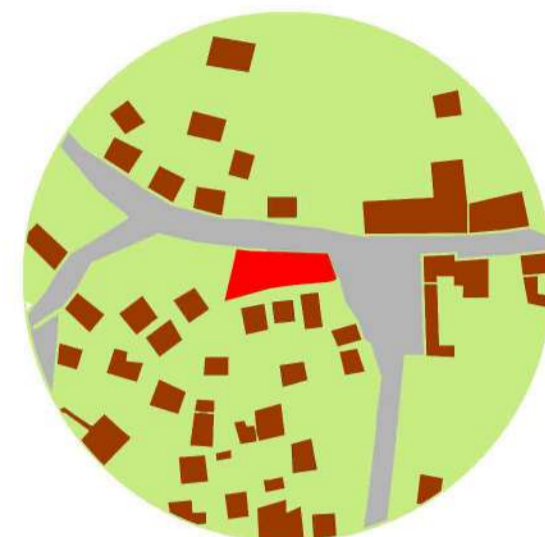

SITE SORROUNDINGS

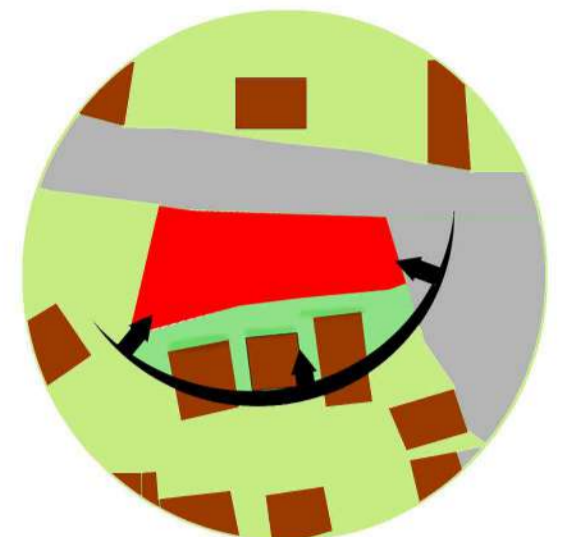

SUNPATH

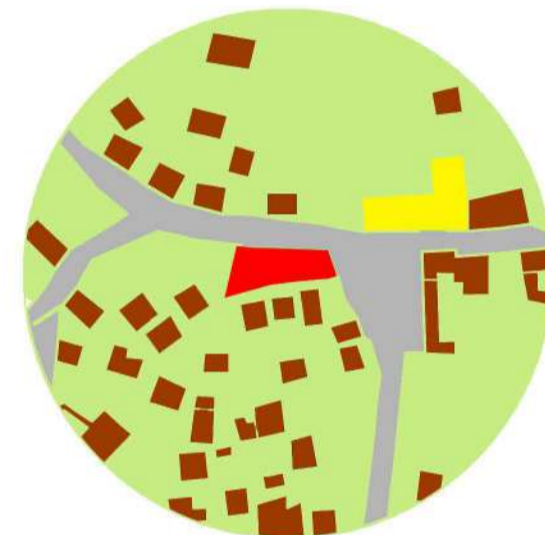

EXISTING LANDSCAPE

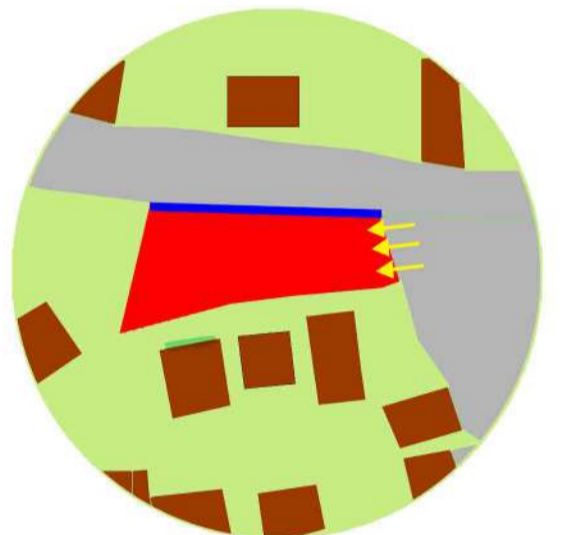

PEOPLE FLOWS

■ RESIDENTIAL (PRIVATE SPACE) ■ FRONT FACADE & ACCESS
 ■ HOTEL (PUBLIC SPACE) ■ ACCESS

CONCEPT :

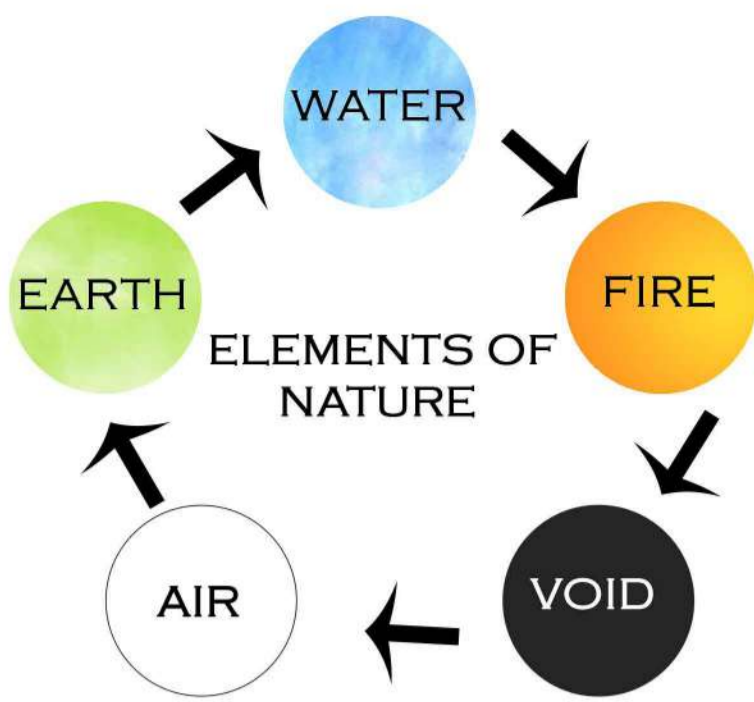

WATER- CONSTITUTE OF ALL LIVING BEINGS
FIRE - CONSUMPTION
VOID - ENDLESS
AIR - LIFE GIVER
EARTH - PRODUCTION , MOTION

● SYMBOL OF TOGETHERNESS



LINE OF SYMMETRY

THIS SYMBOL IS SEEN ON MANY TRADITIONAL BASKETS AND POTTERY. IT'S UTILIZED WHEN THE MAKER WISHES YOU A LIFE OF TOGETHERNESS OR TO SERVE AS A REMINDER OF ITS IMPORTANCE

● STRONG CENTRE :



AS THE SITE IS LOCATED IN THE CENTRE OF LAZAROPOLE VILLAGE, WE INTRODUCE OUR 3RD CONCEPT AS STRONG CENTRES FROM THE DESIGN PRINCIPLES OF AR.ALEXANDER CHRISTOFFE

STRONG CENTERS ARE FORMED WHEN A SUBSTANTIAL REGION SPACE IS TIED TOGETHER COHERENTLY. IT IS USEFUL TO DISTINGUISH TWO TYPES OF CENTERS — "DEFINED", AND "IMPLIED".

● DESIGN PROCESS

THE DESIGN PROCESS INVOLVES ,INCORPORATING ELEMENTS OF NATURE,ACTIVITIES WHICH CELEBRATES TOGETHERNESS & SUSTAINABLE MATERIALS INTO THE SYMBOL OF TOGERHERNESS.

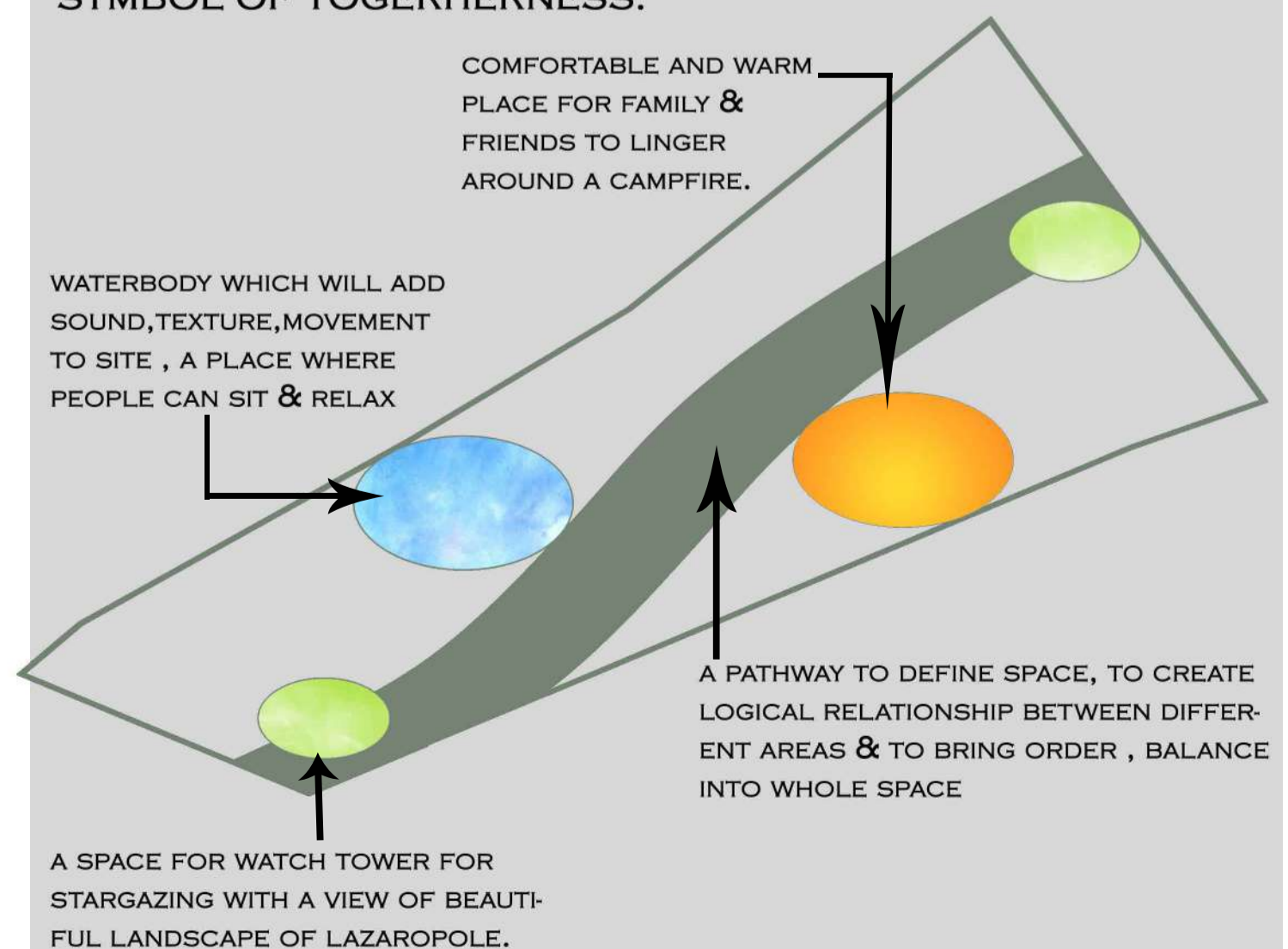

● TOGETHERNESS :



SOCIAL SPACES



SENSE OF WELCOME



CREATE CONNECTIONS

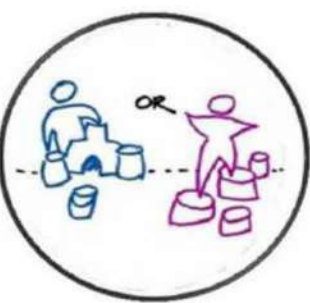

VARIETY & CHOICE



NATURAL MATERIALS



STIMULATE IMAGINATION

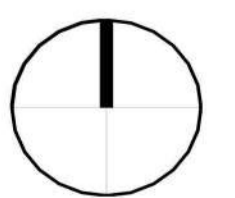
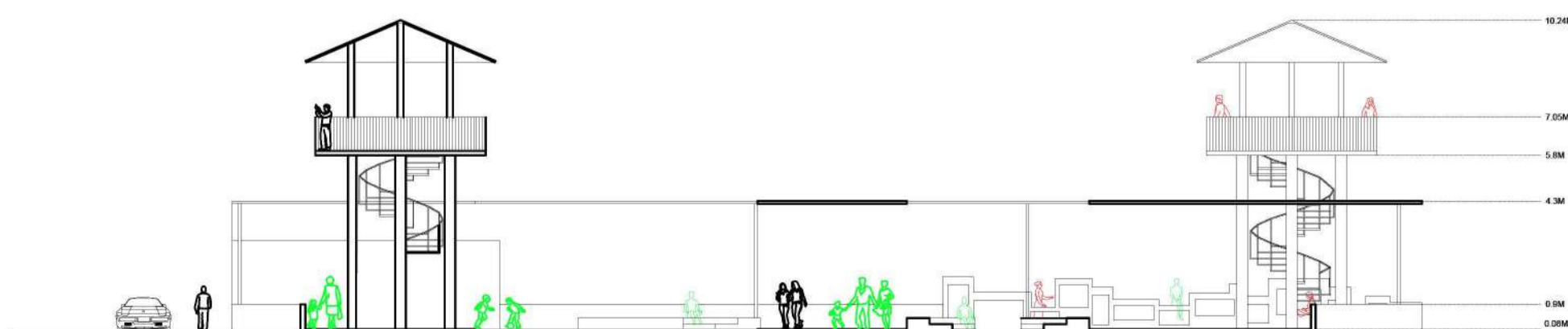
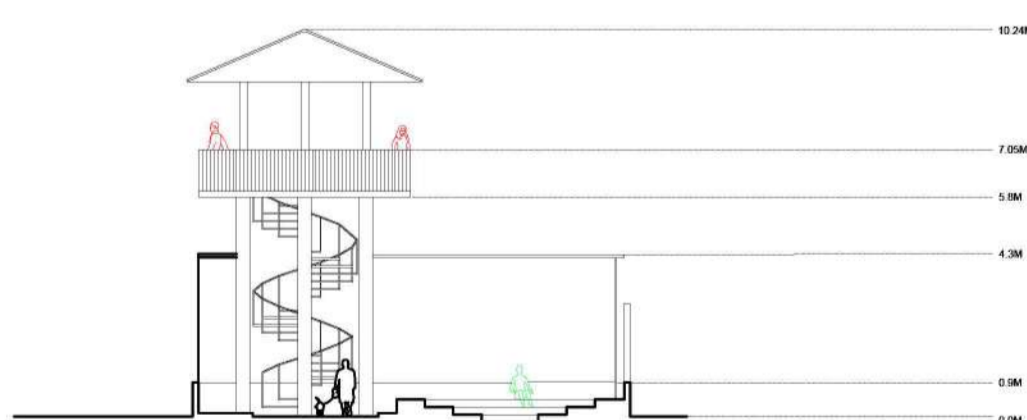
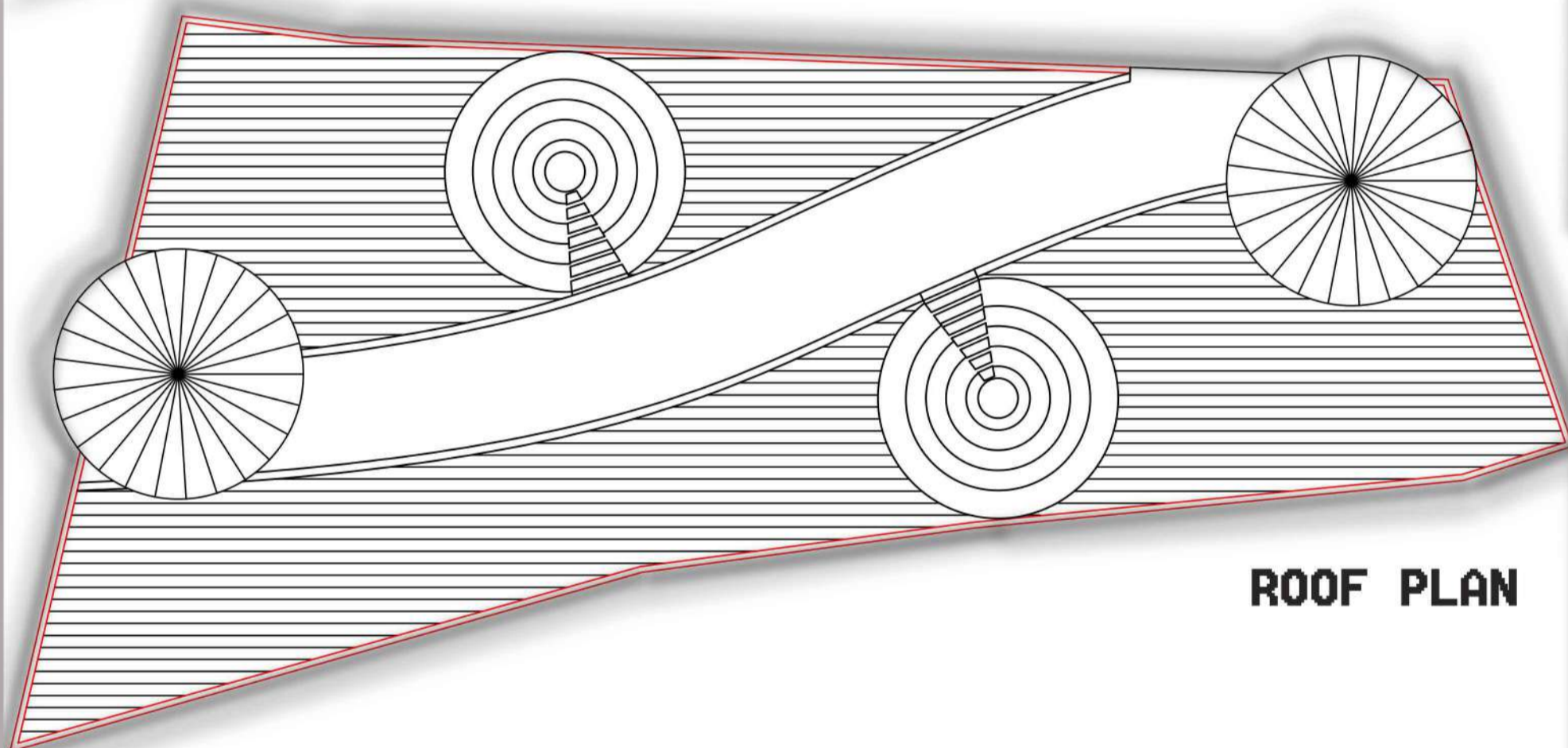
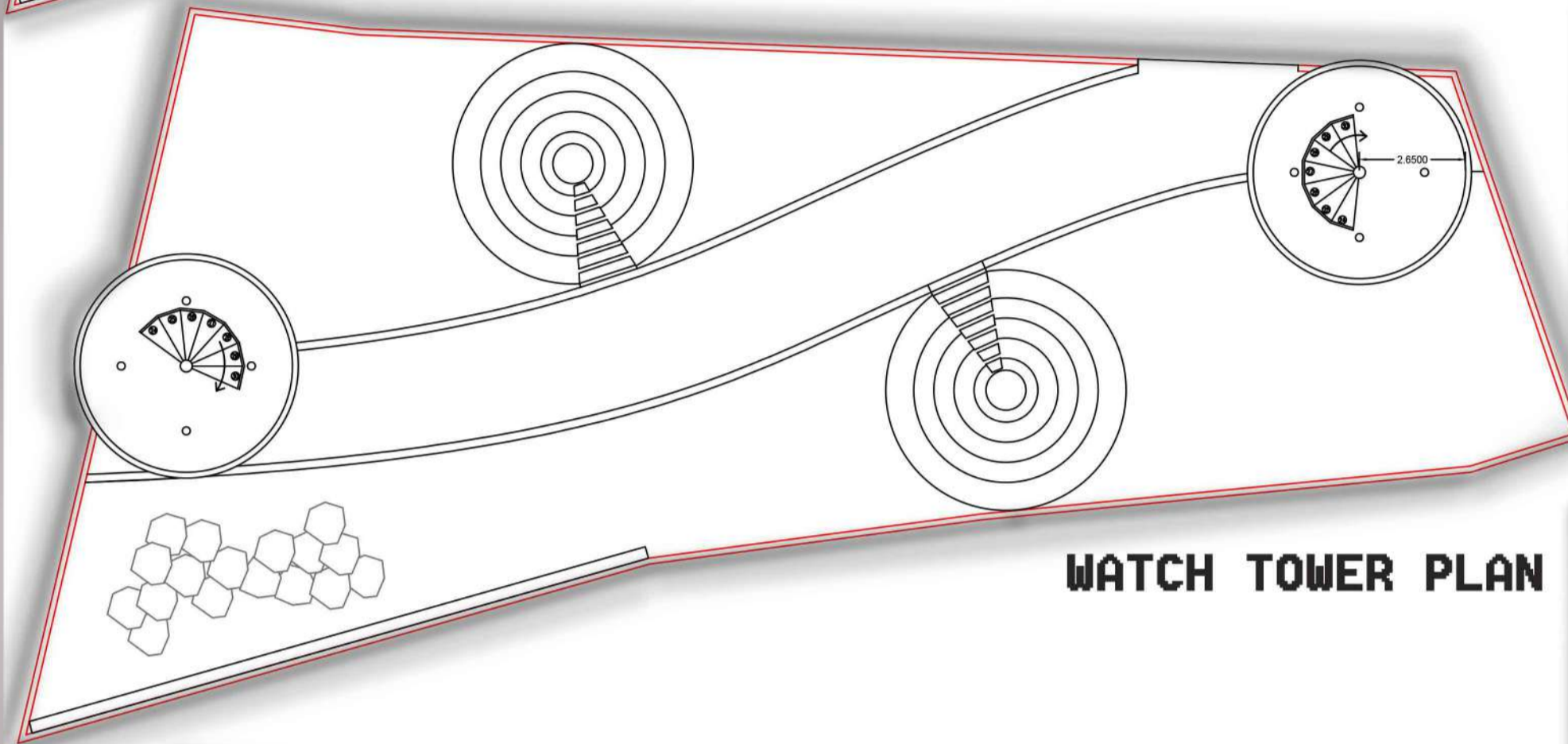
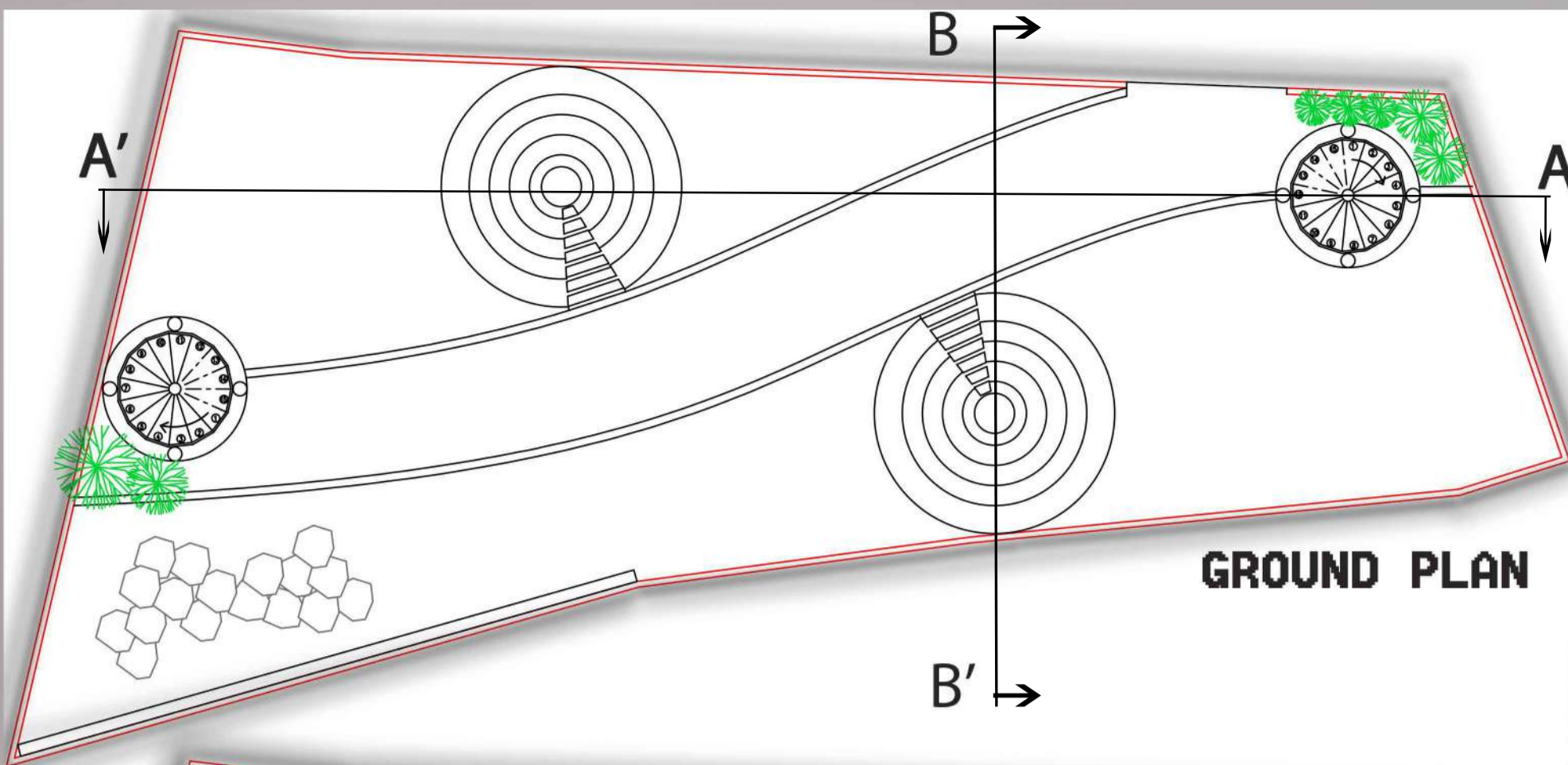

SCALE -1:200

VIEWS AND ELEVATIONS

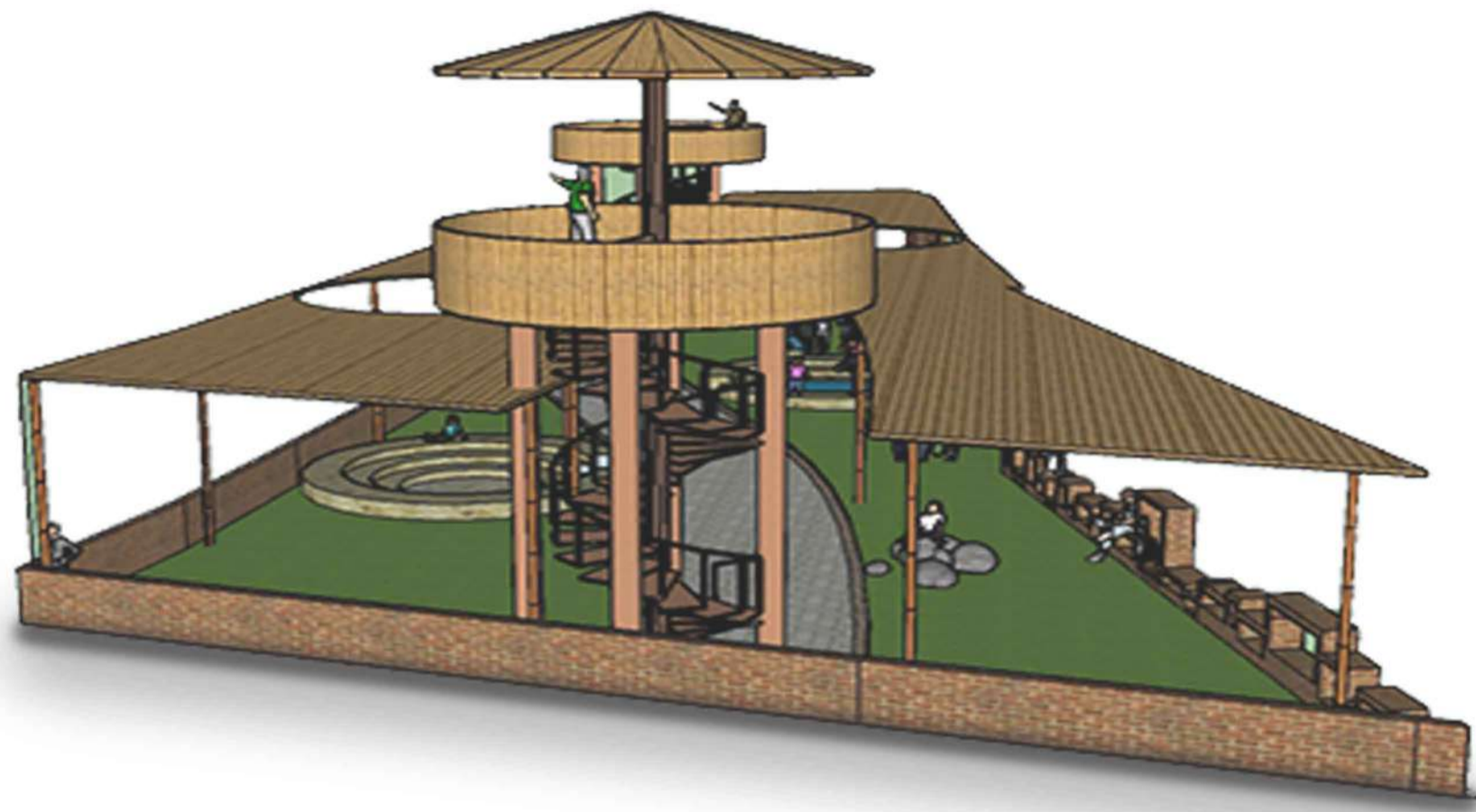

NORTH ELEVATION



SOUTH ELEVATION

